

## Design and Fabrication of Electric-Cargo Vehicle

D. V. Sreekanth<sup>1</sup>, D. Sai Pratyush<sup>2</sup>, Amrith Konda<sup>3</sup>, B. Vikas Pawar<sup>4</sup>, G. Manoj Kumar<sup>5</sup>, N. Varshini<sup>6</sup>  
<sup>1,2,3,4,5,6</sup>Department of Mechanical Engineering, St. Martin's Engineering College, Secunderabad, India

**Abstract**— In recent years, the automotive industry has been looking forward to manufacture electric vehicles (EV) which are completely pollution free. This project mainly concentrates on conversion of an IC Engine Vehicle to a Completely Electric vehicle (Cargo/Commercial Goods vehicle). Here, The IC engine is replaced with a 3Kw 60v 3-Phase BLDC Electric Motor (Brushless D.C) fitted to the Gearbox of IC Engine. Gearbox has four Forward Gears and one Rear Gear. The BLDC motor is connected to a 60v Controller which controls the motor. Li-Ion Battery of 60V 100Ah is used. A 10Amp charger is used to charge the battery, which usually takes 6 to 8 hours to fully charge. Battery is placed under the Driver's Seat with a proper cooling system and protection from water. This paper consists of details of the design and development of electro cargo vehicle which make use of electric energy as primary source.

**Keywords** — BLDC Electric Motor; Li-Ion Battery; 60V Controller; Electric Vehicle

### I. INTRODUCTION (Heading 1)

Electric Vehicles (also known as electric cars or Plug-in electric vehicles) are connected, fun, and practical. They reduce pollution and are even very cheap to use and maintain when compared to Conventional I.C Engine Vehicles.

Using electricity as fuel has a few merits which are not available in Conventional I.C Engine vehicles. We know that electric motors react quickly and instantaneously, Electric Vehicles have instant high torque and are quite responsive. They are also digitally connected with the option to control charging from a smartphone app. Just like a Mobile Phone, you can plug in your EV when you get home and have it ready for you to use the next morning. By charging often, you may never need to go to a Petrol bunk again!

The infrastructure for electric vehicles charging in India has not been fully developed yet. Few initiatives have been taken to set up community charging stations, as in the case of Plugin India facilitated charging stations. News reports have indicated plans to provide solar-powered charging points at the existing Petrol Bunks of the country. India stands at 4th Place in No. of Barrels used in a day with 37.35 Lac Barrels/day. In 2017, Transport Minister Nitin Gadkari shocked the world (and the automobile industry) when he announced that he intended for India to move to 100% electric cars by 2030. EVs provide more than just individual benefits. Electric Vehicles can also reduce the emissions that contribute to climate change and smog, improving public health and reducing ecological damage. These emissions can be minimized by Charging your EV on renewable energy such as solar or wind.

The above are the few main reasons behind this project. We know that, in India, 60% of the goods and cargo are transported by road. Electric vehicles on road include Trains, Buses, Cars, Autos and Bikes. Very few industries like BHEL, Visakhapatnam Steel Plant designed and developed cargo vehicles for their own use. Our project will be available for a common man to commence Cargo Transportation within the city.

Our project consists of a BLDC motor fitted to a 4-speed Sequential gearbox which is connected to the rear axle of the vehicle. A Li-ion battery supplies the electric power to run the BLDC motor through a 60V Controller Hub. This controller hub acts as an operating Centre. The accelerator is connected to the controller itself. The Li-ion Battery is charged using a 10Amps Charger.



Fig.1 Electric Cargo Vehicle

### A. Components of Electric Cargo Vehicle

The following are the components of Electric-Cargo Vehicle

- **BLDC Motor:** The full form of BLDC Motor is Brushless DC Motor which are powered by Direct current (DC) Electricity via Battery which produces electricity in the form of alternating current (AC) to drive each phase of the motor via a controller. The Speed and Torque are controlled by Pulses of current which are provided by the controller to the motor windings. The brushless motors have an advantage over brushed motors. Brushless Motors have a high power-to-weight ratio, high speed, electronic control, and low

maintenance. Brushless motors have many applications such as computer components (disk drives, printers), Hand-held power tools and vehicles ranging from Concept aircraft to Working Automobiles.

For this project, A 3KW 60V (Three-phase) Air Cooled BLDC motor is used. This BLDC Motor can accommodate a shaft as shown in Fig. 2 and Fig. 3.



Fig. 2 BLDC Motor Front Side



Fig. 3 BLDC Motor Rear Side

- Li-Ion Battery Pack and Charger:** A Li-ion battery (Lithium-ion battery) is a type of rechargeable battery which are commonly used for portable electronics and electric vehicles. In this type of batteries, the lithium ions move from the negative electrode through a medium of electrolyte to the positive electrode during discharge, and back while charging. Features are Low cost, Low toxicity, Well-defined performance, Long-term stability. One important advantage over other chemistries is Thermal and Chemical stability. A Battery Management System is used to equally charge and discharge each and every individual Li-ion Cell. (Nakajima, 2015) [1]

In this project, A Li-ion Battery Pack of 60v 100Ah with Dual-BMS wrapped around insulation material to ensure safe running. This whole battery pack is placed inside a WPC (Wood-Plastic Composite) Cuboid Box (Wood-Polymer Composite Material) which is both fire and water resistant. This Battery Pack consists of 350 Li-ion Cells as shown in Fig. 4.

The Model Number is 18650 Li-ion cells. A 10Amps Charger is used to charge this Battery Pack. It takes 8 to 10 hours to charge and has a theoretical range of 80 to 90 km.

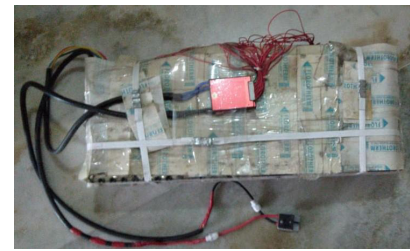

Fig. 4 Lithium-ion Battery Pack (60V 100Ah)



Fig. 5 Battery Charger (10Amps)

- Controller:** Motor controller is a device that serves to govern in some predetermined manner the performance of an electric motor. It includes a Manual/Automatic means for starting and stopping the motor, selecting forward or reverse rotation, selecting and regulating the speed, regulating or limiting the torque, and protecting against



overloads and electrical faults.

Fig. 6 Motor Controller (60V)

## II. OBJECTIVE

The main objective of this research is to convert a Diesel-Powered Light motor commercial vehicle, which has an engine failure, to a fully electric Light motor commercial vehicle which can be used for economic transportation of goods

## III. LITERATURE REVIEW

### A. Need for electric vehicles

In this highly evolving technological era, the need for renewable and clean energy is very essential for a

sustainable future. The use of electric vehicles is a step forward in this direction to decrease the use of fossil fuels as the primary fuel source. The best place to increase transportation efficiency is by reducing the carbon dioxide (CO<sub>2</sub>) emissions, which is the major culprit in global warming. In the United States, about 33 percent comes from CO<sub>2</sub> emissions by transportation.

With gasoline-electric hybrid power and all-electric power, we can achieve remarkable cost and environmental savings. By escalating the number of batteries and recharging capacity to gasoline-electric hybrid vehicles, we can have plug-in hybrids that offer the range of hybrids (800kms or more), plus the advantage of all-electric power for short trips, which stupendously decreases the amount of gasoline used. EVs require no gasoline whatsoever and, when recharged from renewable energy sources, generate zero total emissions. (Heckerroth, 2006) [2]

In fact, even if we switched from gasoline cars to EVs and plug-in hybrids recharged by our existing utility grids (which mostly use fossil fuels), we would see reduction in CO<sub>2</sub> emissions of about 42 percent national average, according to research by Peter Lilienthal of the National Renewable Energy Laboratory. (Lilienthal, 2013) [3]

*Current status of electric vehicles in India*

In India, the charging infrastructure for electric vehicles has not been fully developed yet. There have been various schemes to set up community charging stations, as in the case of Plugin India paved the path to set up charging stations. Their main goal is to popularize the concept of community charging stations. The idea is for businesses / resorts / vacation homes etc., which are at a distance of 40-70 km around cities to set up normal 15 Amp charge points or Smart EVSE for electric cars and next generation electric bikes. (Plu) [4]

Other companies like Tata Power, Fortum and a few others which are tied up in the industry of electric vehicle charging, have already set up an array of chargers – rapid DC chargers and level 2 AC chargers for all kinds of applications - public access, workplace charging, fleet charging, residential communities, malls, highways etc. and have large plans to scale up.

Charging infrastructure, mostly setting up of level 2 charging at public level shall be the arduous dare in terms of service incorporation for India. For normal charging, the charging time poses a grave issue as it ranges from 6 to 8 hours whereas for fast DC charging; cost & high renewable energy are the extensive factors which could give rise to an issue. It is also assumed that 10% of the charging infrastructure desired in India shall be constituted of fast charging stations and rest 90% shall come from level 2 public charging setups. (Wik) [5]

*B. Lack of renewable energy and grid infrastructure*

In India electricity is primarily produced by burning coal, which generates an immense amount of greenhouse emissions. With the development of EVs and charging infrastructure, the electricity requirement will go up a lot

and the whole point of introducing EVs to reduce GHG emissions would be successful, if all this electricity was generated by burning coal. Moreover, India's Distribution companies hold debts and are unable to suffice the energy requirement of the whole country adequately. If EVs were to enter this equation, the sudden increase in electricity requirement would put extra load on these companies. Moreover, there are a lot of factors that would go into deciding pricing of the electricity as well the demand on the grid. (Ali, et al., 2018) [6]

Public charging infrastructure and electric vehicle registrations per million population by metropolitan area, with size of circles indicating total electric vehicles – India & Global Comparison

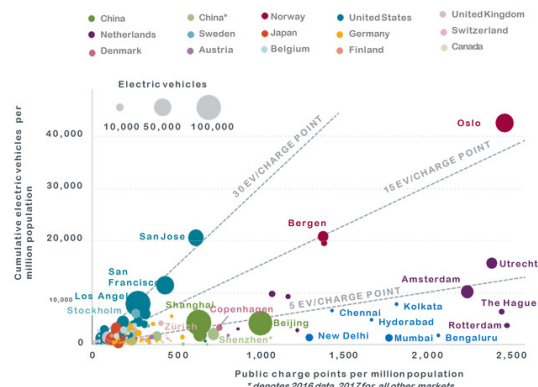

Source: enincon research & analysis and ICCT White Paper on EV

Fig. 7 Public charging infrastructure and electric vehicle registrations per million population by metropolitan areas (Lutsey, et al.) [7]

*C. Electric vehicles in transportation industry*

The following companies have launched electric pick-up trucks in India:

- ECOYAN
- Mahindra
- Tata Motors, Ace Electric in 2016
- Ashok Leyland, Dost Electric pick-up truck
- Croyance Automotive, ELECRO 1.t India first electric cargo light truck

A Gurgaon based startup – Infraprime logistics Technology (IPLT), has launched an all-electric truck, which was fully designed, developed and built indigenously. This is also the first electric vehicle in India to sport an automatic transmission for a two – speed operation. A truck is essentially a medium-level logistics vehicle for transporting, for example, aggregates from mines for construction sites, cement companies, etc. The claimed range between charges is 400 km (without payload) and 200 km (with load). It can handle a 20-degree gradient, which is higher than diesel trucks. (Singh, 2019) [8]

#### IV. PROBLEM DEFINITION

About 60% of the goods are transported by Trucks, Lorries, Tuskers and Light Motor Commercial Vehicles. Most of the goods are transported within a city by Light Motor Commercial Vehicles. Nowadays, the major concern of the government is to find out a way by which we can minimize use of fossil fuel and promote the use of electric vehicles in our daily life because they don't produce air pollution when compared to Regular IC Engine Vehicles. Recent fuel prices have hit the people hard economically. Table I and Table II show the specifications of the vehicle and specifications of the parts respectively.

##### D. Assembly of BLDC Motor

In this project, A Diesel-Powered Light motor commercial vehicle (Mahindra Gio), has been chosen, which has an engine failure. This vehicle is converted into a fully electric Light motor commercial vehicle. This paper consists of procedure followed for conversion of Diesel Vehicle to Fully Electric Vehicle. The Diesel Engine of the Cargo vehicle is disassembled. The Gearbox is then fixed to the rear axle of the Vehicle.



Fig.7 Diesel Engine with Gearbox

A shaft is needed to connect the BLDC Motor and the gearbox. A Stainless-Steel Rod of Grade 303 is machined according to our required dimensions. Proper supports for BLDC Motor are provided.

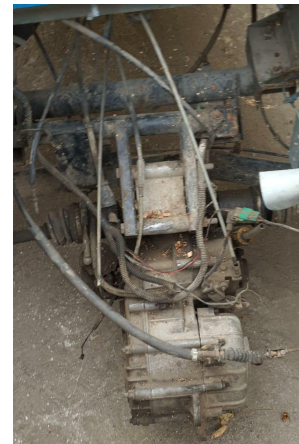

Fig.8 Gearbox without Diesel Engine



Fig. 9 Connecting shaft between BLDC Motor and Gearbox

##### E. Working

After fitting the BLDC motor to the gearbox, the components are connected as shown in fig.11. The battery is placed under the Driver's Seat along with the charging port. The controller is fixed to the chassis bed. The controller sends power from the battery to the BLDC motor whenever the driver pushes the accelerator pedal. This is a Manual-Type Transmission system.

##### F. Design Procedure

Design of frame – Wheels and Brakes – Design of Bodyworks – Fabrication of Chassis – Fabrication of parts of the Chassis – Assembly of parts – Body and Composites – Driving and Testing. Fig. 10 shows the

layout and connections of all the components of the electric cargo vehicle.

TABLE I. Specifications of the Vehicle

Type	Dimensions
Wheel Base (mm)	2005
Overall Width (mm)	1460
Overall Length (mm)	3180
Overall Height (mm)	1815
Front Track (mm)	1060
Rear Track (mm)	1260
Minimum Ground Clearance (mm)	180
Cargo Box Dimensions (mm)	1570 × 1460 × 380

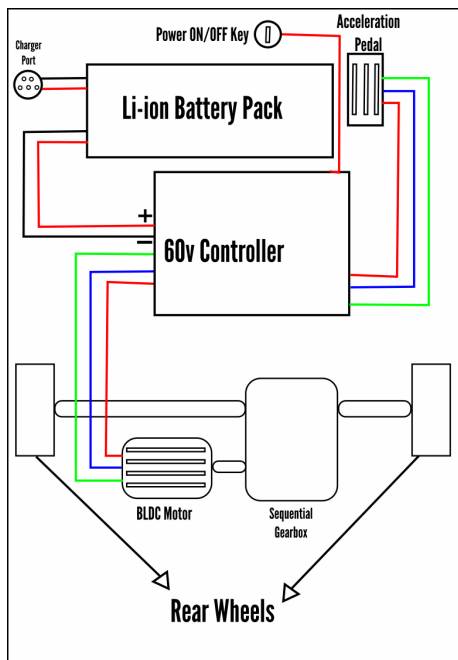

Fig. 10 Layout of the Components

TABLE II. Specifications of Components

S. No.	Component/Part	Details
1	BLDC Motor	3kW – 60V – 3 Phase Brushless Dc Motor
2	Clutch	Type: Multi – Plate Wet Clutch
3	Gearbox	4 – Speed Sequential Gearbox
4	Suspension	Front: Independent suspension with MacPherson Strut Rear: Spring with telescopic shock absorber
5	Brakes	Front: Hydraulic Rear: Drum
6	Battery Pack	Lithium-ion 60V, 100Ah
7	Controller	60V

V. FUTURE SCOPE

The Indian government has set targets to increase the use of electric vehicles by 2023. In December 2019, India’s rank has worsened from the 14th spot in 2017 to 5th in 2018 in the global vulnerability ladder in The Climate Risk Index 2020 released by the environment think tank, Germanwatch e.V.

This makes it all the major reason for India to make electric cars and vehicles a priority in the fight against the exhaust of fossil fuels. While the initial push was seen towards making two-wheelers and three-wheelers electric, the bigger need is for electric public transportation and cars.

VI. REFERENCES

- [1] Tsuyoshi Nakajima, Chapter 7 - Safety Improvement of Lithium Ion Battery by Organofluorine Compounds, Advanced Fluoride-Based Materials for Energy Conversion, Elsevier, 2015, Pages 147-172, ISBN 9780128006795
- [2] Steve Heckerth, [Online]. Available: <https://www.motherearthnews.com/green-transportation/electric-cars-zmaz06onzraw>
- [3] Peter Lilienthal, National Renewable Energy Laboratory, [Online]. Available: <https://www.nrel.gov/>
- [4] Plug in India website. [Online]. Available: <https://www.pluginindia.com/charging.html>
- [5] The Wikipedia website. [Online]. Available: [https://en.wikipedia.org/wiki/Electric\\_vehicle\\_industry\\_in\\_India#Challenges\\_faced](https://en.wikipedia.org/wiki/Electric_vehicle_industry_in_India#Challenges_faced)
- [6] Ali, Mohd. Sahil; Tongia, Rahul (2018). “Electrifying Mobility in India: Future prospects for the electric and EV ecosystem”, Brookings India IMPACT Series No. 052018. May 2018
- [7] Lutsey, Nicholas & Hall, Dale. (2017). Emerging best practices for electric vehicle charging infrastructure. [Online]. Available: [researchgate.net/figure/Public-charging-infrastructure-and-electric-vehicle-registrations-per-million-population\\_fig2\\_320211098](https://researchgate.net/figure/Public-charging-infrastructure-and-electric-vehicle-registrations-per-million-population_fig2_320211098)
- [8] Abhilasha Singh, Financial Express September 19, 2019. [Online]. Available: <https://www.financialexpress.com/auto/car-news/indias-first-all-electric-heavy-duty-60-tonne-truck-by-infraprime-logistics-is-already-in-operation/1711037/>